

AIR-1250-F / AIR-1250-D

HEAT RECOVERY VENTILATOR



ENGINEERING DATA:

CORES

Modular (3 section) patented aluminum heat recovery cores arranged for efficient counter-flow ventilation.

MOTORS

Two PSC, 3 speed double shafted, 120 VAC, 9.4 Amps each (18.8 total on high speed). HP - 1/2, 1625 RPM. Watts - total on high speed - 2256. MCA: 23.5 MOP: 30

FILTERS

Washable air filters in exhaust and supply air streams.

BLOWERS

Slide easily in / out of unit. Centrifugal type rated at 1200 CFM (566 L/s) free air delivery. Each air stream has one double shafted motor driving 2 centrifugal blowers.

CONNECTION DUCT SIZES

Four - 20 in. x 8 in. (508 mm x 200 mm).

MOUNTING

Unit to be set on support brackets hung by threaded rod-type apparatus (brackets and rods not included).

CASE

Unit has front and back access doors and electrical panel can be switched to either side giving the installer flexibility in duct direction. 20 gauge prepainted galvanized steel (G60 for superior corrosion resistance. Insulated with foil faced insulation where required to prevent exterior condensation. Drain connections; two - 1/2 in. (12 mm) O.D.

ELECTRONICS

Integrated microprocessor circuit board. Built-in interlock contacts. Optional remote speed control.

DEFROST CONTROLS

AIR-1250-F - Interrupts supply air while exhaust air defrosts core.

AIR-1250-D - Supply bypass routes indoor air to defrost core.

CONTROL OPTIONS

99-GBCO2 AIRFLOW VENTILATION CONTROL

- 2 speed fan setting (Low/High)
- Humidity control through adjustable Dehumidistat
- Compatible with 99-DET02 Wireless Timers
- 3 wire connection; 20 gauge wire (minimum)

99-500 3 SPEED CONTROL

- 3 Speed Fan setting (Low/Medium/High)
- 4 wire connection; 20 gauge wire (minimum)

TIMERS

99-DET01 AIRFLOW 20/40/60 MINUTE TIMER

- Initiates high speed Ventilation for 20, 40 or 60 minutes
- 3 wire connection; 20 gauge wire (minimum)

99-DET02 AIRFLOW WIRELESS 20/40/60 MINUTE TIMER

- Initiates High speed Ventilation for 20, 40 or 60 minutes. Wirelessly connects to main control for ease of installation. 40' approximate range.

99-RX02 AIRFLOW WIRELESS REPEATER

- Used to extend range of 99-DET02 Wireless Timers when timers are out of range
- Plugs into 120V power outlet and wirelessly connects to main control and 99-DET02

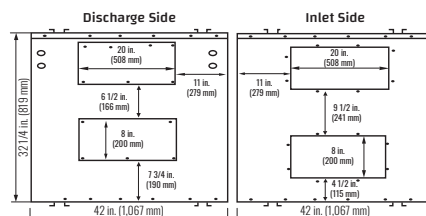
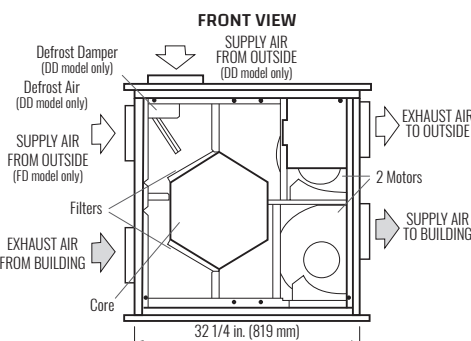
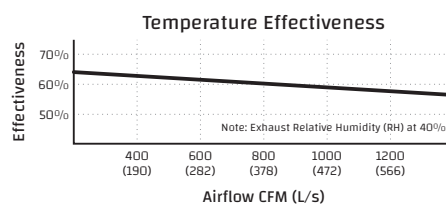
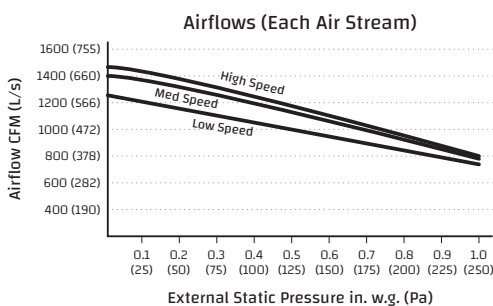

Airflow:

- ➡ Stale Air to Outside
- ➡ Fresh Air from Outside
- ➡ Stale Air from Inside
- ➡ Fresh Air to Inside

WEIGHT:
285 LBS (130 KG)

SHIPPING WEIGHT:
335 LBS (152 KG)

Note: Service clearance is 30 in. (760 mm) from front access doors. All specifications are subject to change without notice.

AHRI 1060 Certified Core:
Contains three 68-222

MERV 13 Upgrade: 65-195-6R



WARRANTY

Units carry a 15 year warranty on HRV core and 2 year replacement parts warranty.